

FLL800IQ-2C

L-Band High Power GaAs FET

FEATURES

- Push-Pull Configuration
- High Power Output: 80W (Typ.)
- High PAE: 50% (Typ.)
- Broad Frequency Range: 2100 to 2200 MHz.
- Suitable for class AB operation.

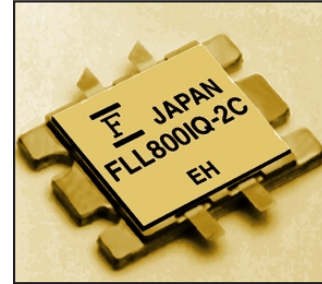

DESCRIPTION

The FLL800IQ-2C is a 80 Watt GaAs FET that employs a push-pull design that offers ease of matching, greater consistency and a broader bandwidth for high power L-band amplifiers. This product is targeted to reduce the size and complexity of highly linear, high power base station transmitting amplifiers. This new product is uniquely suited for use in W-CDMA and IMT 2000 base station amplifiers as it offers high gain, long term reliability and ease of use.

APPLICATIONS

- Solid State Base-Station Power Amplifier.
- W-CDMA and IMT 2000 Communication Systems.

ABSOLUTE MAXIMUM RATINGS (Ambient Temperature $T_a=25^\circ\text{C}$)

Item	Symbol	Condition	Rating	Unit
Drain-Source Voltage	V_{DS}		15	V
Gate-Source Voltage	V_{GS}		-5	V
Total Power Dissipation	P_T	$T_c = 25^\circ\text{C}$	136	W
Storage Temperature	T_{stg}		-65 to +175	$^\circ\text{C}$
Channel Temperature	T_{ch}		+175	$^\circ\text{C}$

Fujitsu recommends the following conditions for the reliable operation of GaAs FETs:

1. The drain-source operating voltage (V_{DS}) should not exceed 12 volts.
2. The forward and reverse gate currents should not exceed 176 and -51.8 mA respectively with gate resistance of 10 Ω .
3. The operating channel temperature (T_{ch}) should not exceed 145 $^\circ\text{C}$.

ELECTRICAL CHARACTERISTICS (Case Temperature $T_c=25^\circ\text{C}$)

Item	Symbol	Conditions	Limits			Unit
			Min.	Typ.	Max.	
Drain Current	I_{DSS}	$V_{DS} = 5\text{V}, V_{GS} = 0\text{V}$	-	8	-	A
Pinch-Off Voltage	V_p	$V_{DS} = 5\text{V}, I_{DS} = 220\text{mA}$	-0.1	-0.3	-0.5	V
Gate-Source Breakdown Voltage	V_{GSO}	$I_{GS} = -2.2\text{mA}$	-5	-	-	V
Output Power	P_{out}	$V_{DS} = 12\text{V}$ $f = 2.17\text{GHz}$	48.0	49.0	-	dBm
Linear Gain	GL		10.0	11.0	-	dB
Drain Current	I_{DSR}		-	11.5	15	A
Power-Added Efficiency	η_{add}	$I_{DS} = 2.0\text{A}$ $P_{in} = 40.0\text{dBm}$	-	50	-	%
Thermal Resistance	R_{th}	Channel to Case	-	0.8	1.1	$^\circ\text{C/W}$

CASE STYLE: IU

FLL800IQ-2C

L-Band High Power GaAs FET

OUTPUT POWER vs. ACPR

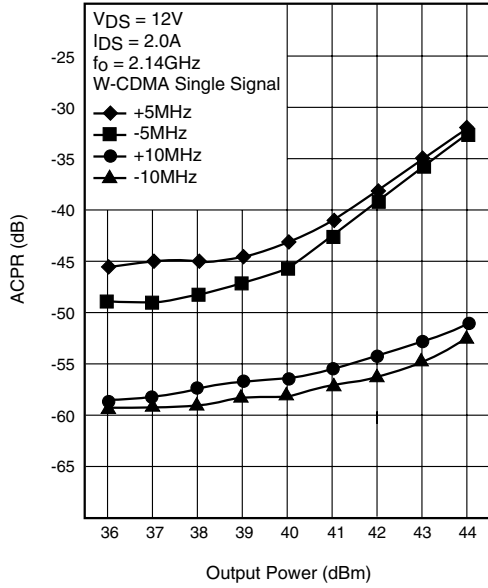

OUTPUT POWER vs. IMD

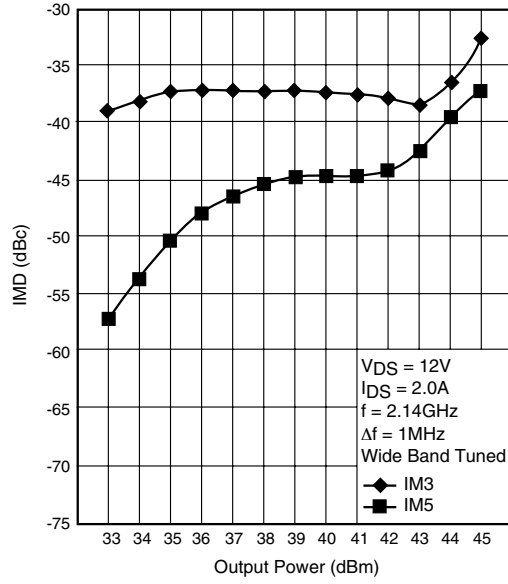

OUTPUT POWER vs. FREQUENCY

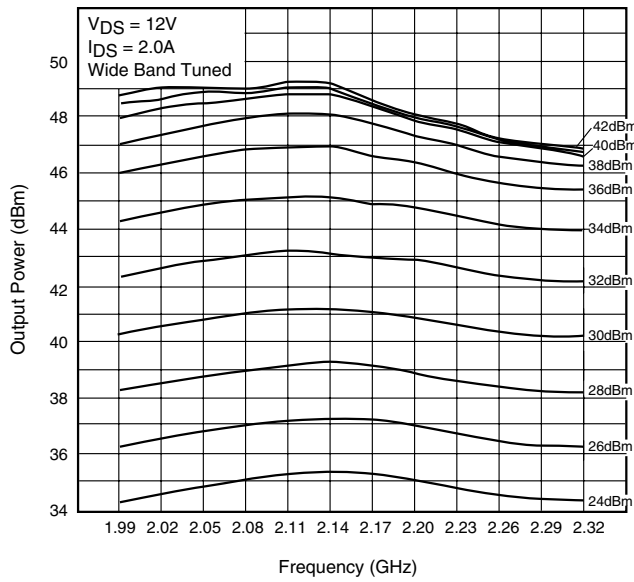

OUTPUT POWER vs. INPUT POWER

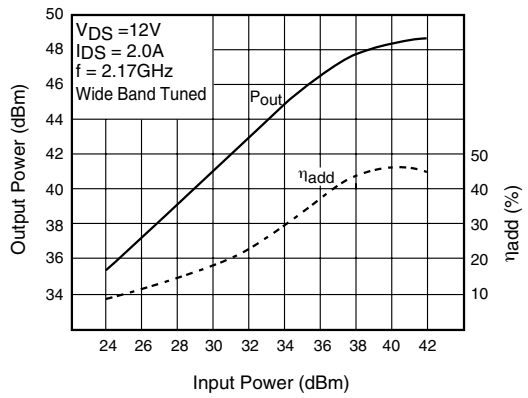

FLL800IQ-2C

L-Band High Power GaAs FET

S-PARAMETERS

$V_{DS} = 12V, I_{DS} = 1000mA$

FREQUENCY (MHZ)	S11		S21		S12		S22	
	MAG	ANG	MAG	ANG	MAG	ANG	MAG	ANG
1000	.933	168.4	.636	61.5	.010	58.6	.879	173.1
1100	.925	166.9	.662	56.8	.012	54.2	.864	172.5
1200	.907	164.8	.715	50.9	.014	55.9	.855	172.1
1300	.885	163.1	.772	43.8	.017	50.8	.840	172.0
1400	.852	161.0	.851	35.7	.019	47.4	.823	172.1
1500	.814	159.2	.957	25.8	.023	37.4	.812	172.8
1600	.764	157.6	1.085	14.0	.025	32.8	.809	173.7
1700	.705	157.4	1.211	0.4	.030	17.9	.821	174.9
1800	.650	159.0	1.324	-13.9	.032	8.1	.840	175.3
1900	.616	162.5	1.422	-30.5	.033	-9.4	.870	174.4
2000	.601	165.8	1.492	-46.2	.033	-23.9	.891	172.2
2100	.599	169.9	1.579	-62.8	.030	-38.8	.893	168.7
2200	.617	172.1	1.635	-79.4	.029	-50.9	.869	165.4
2300	.630	174.1	1.744	-95.0	.026	-77.7	.831	160.6
2400	.669	175.7	1.873	-113.0	.022	-98.0	.752	157.3
2500	.723	175.5	2.012	-132.3	.017	-127.2	.651	157.7
2600	.793	170.9	2.002	-156.1	.012	-179.3	.554	164.9
2700	.842	162.6	1.892	-179.5	.014	120.4	.544	176.7
2800	.852	151.8	1.685	158.7	.018	83.4	.604	-176.3
2900	.832	138.5	1.503	139.9	.025	53.4	.679	-174.2
3000	.769	120.4	1.373	121.8	.033	38.1	.739	-175.0
3100	.670	94.8	1.312	103.6	.036	14.4	.794	-176.6
3200	.509	53.4	1.197	79.9	.044	-13.0	.837	-178.9
3300	.272	-1.0	.890	58.7	.037	-41.7	.867	177.8
3400	.346	-37.6	.777	49.6	.026	-37.4	.871	174.8
3500	.444	-59.4	.772	36.0	.027	-34.1	.878	172.8
3600	.651	-86.0	.644	11.8	.026	-42.2	.889	170.2
3700	.745	-106.1	.498	-3.6	.027	-48.4	.890	167.9
3800	.794	-119.8	.391	-13.3	.025	-41.2	.893	165.6
3900	.818	-129.7	.344	-19.5	.027	-50.0	.891	163.2
4000	.843	-137.8	.302	-26.2	.023	-41.8	.891	160.9
4100	.856	-145.1	.281	-31.0	.026	-35.5	.892	158.0
4300	.860	-158.2	.261	-43.6	.046	-24.0	.890	151.8
4400	.840	-166.0	.260	-47.9	.076	-18.7	.887	147.7
4500	.746	-179.8	.318	-48.1	.157	-33.6	.874	141.9

Note: This S-Parameter data shows measurements performed on a single-ended push-pull FET. These parameters should be used to determine the calculated Push-Pull S-Parameter amplifier designs.

FLL800IQ-2C

L-Band High Power GaAs FET

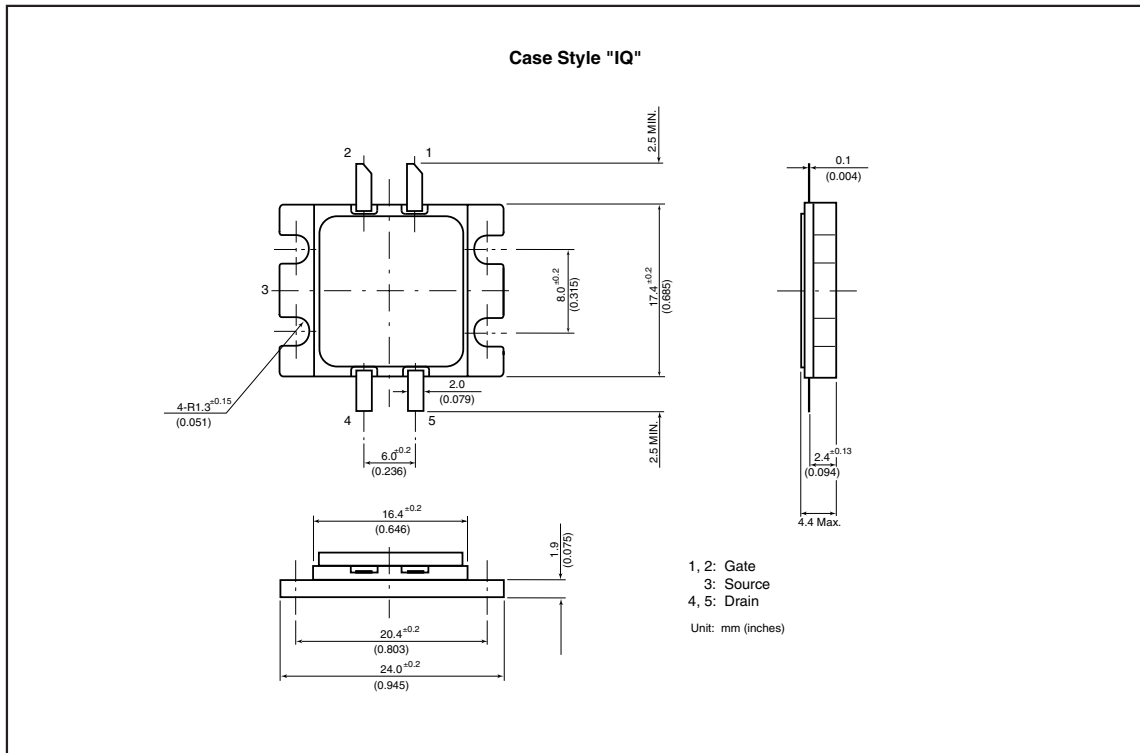

For further information please contact:

FUJITSU COMPOUND SEMICONDUCTOR, INC.

2355 Zanker Rd.
San Jose, CA 95131-1138, U.S.A.
Phone: (408) 232-9500
FAX: (408) 428-9111
www.fcsi.fujitsu.com

FME, QDD (European Sales Office)

Fujitsu Microelectronics Europe GmbH
Quantum Devices Division
Network House
Norreys Drive
Maidenhead, Berkshire SL6 4FJ
Phone: +44 (0)1628 504800
FAX: +44 (0)1628 504888

CAUTION

Fujitsu Compound Semiconductor Products contain **gallium arsenide (GaAs)** which can be hazardous to the human body and the environment. For safety, observe the following procedures:

- Do not put these products into the mouth.
- Do not alter the form of this product into a gas, powder, or liquid through burning, crushing, or chemical processing as these by-products are dangerous to the human body if inhaled, ingested, or swallowed.
- Observe government laws and company regulations when discarding this product. This product must be discarded in accordance with methods specified by applicable hazardous waste procedures.

Fujitsu Limited reserves the right to change products and specifications without notice.
The information does not convey any license under rights of Fujitsu Limited or others.
© 1999 FUJITSU COMPOUND SEMICONDUCTOR, INC.
Printed in U.S.A. FCSI1199M200